



Description of the hygrostat

The humidity measuring element, produced by Galltec under the name Polyga®, consists of several synthetic fabric bands each with 90 individual fibres with a diameter of 0.003mm. A special process gives the fibre hygroscopic properties. The measuring element absorbs and desorbs humidity. The swelling effect, which is predominantly in a lengthways direction, is carried via a suitable lever system to a microswitch with an extremely small switching path. The measuring element reacts quickly and precisely to the change in air humidity. By adjusting the set value control knob, the lever system is engaged so that when the set air humidity is reached the microswitch is activated.

In the case of the hygrostat type HG120-2, a second microswitch is positioned parallel to the first microswitch. After the housing cover has been removed, the second set value can be finely adjusted at the microswitch lever using a screwdriver. The switch point of the second microswitch is connected to the switch point of the first microswitch. The switch distance (neutral zone) can be set from 3%rh to +15%rh.

The fan-shaped measuring element is accommodated inside the housing and must be protected against coarse dust, dirt and water. The sensors are designed for pressureless systems. The mounting position should be chosen such that condensed water cannot get into the interior of the housing. Any mounting position is possible, preferably with ventilation slots across the direction of wind.

Maintenance

The measuring element is maintenance-free in pure ambient air. Aggressive media containing solvent can cause measuring errors and failure, depending on the type and concentration. As with almost all humidity measuring elements, deposits which eventually form a water-repellent film over the sensor are harmful. Such substances are resin aerosols, lacquer aerosols, smoke deposits etc.

NOTE:

Contact with the inner parts nullifies the guarantee

Room Hygrostat

measuring range 30...100%rh

HG120
HG120-2
HG120i

Application

The hygrostat type **HG120** is used as an on-off controller to control the relative air humidity in climatic cabinets, to control air humidifiers and dehumidifiers in offices and computer rooms. Other areas of use are storage of foodstuffs and luxury foods, cooling rooms for fruit and vegetables, greenhouses for gardening use, the textile industry, the paper and printing industry, the film industry and hospitals. The hygrostat **HG120** can be used almost anywhere that air humidity has to be regulated or monitored.

The room hygrostat **HG120-2** is equipped with a 2nd microswitch. It can be used as a 2-level controller or as a max-min controller.

Room hygrosats with internal scale are available for all variations. The type designation has a small "i" at the end, e.g. **HG120i**.

Technical Data

scale range 30...100%rh
 measuring accuracy ±3.0%rh
 range of operation 35...95%rh
 switching difference (microswitch) ref. to 50%rh
 approx. 4%rh

microswitch:

breaking capacity, *maximum load*

ohmic load "humidify" 2A, 230V AC

"dehumidify" 5A, 230V AC

inductive load* cos φ=0.7 1.0A, 230V AC

breaking capacity, *min* 100mA, 20V DC / AC

lifetime 100.000 cycles

recommended voltage 24V AC

max. voltage 250V AC 50 Hz

Please observe the notes on voltage.

optional: microswitch with gold contact:

breaking capacity, *max* 100mA, 48V AC

breaking capacity, *min* 1mA, 5V

allowable ambient temperature 0...60°C

medium temp. coefficient -0.2%/K rel. to 20°C and 50%rh

adjustment at average air pressure 430 m NN

allowable air speed 15m/sec

t₅₀ at v=2m/sec 1.2min

fixing slots in housing base

mounting position preferably ventilation slots at

right-angles to wind direction

contacting connecting terminal in the case

electromagnetic compatibility EMC

resistance to interference ref. EN 50 082-2

interference emission ref. EN 50 081-2

housing solid plastic, light grey

protective system IP20

measuring element

..... Polyga®-measuring element, water resistant

dimensions 115x70x47mm

weight approx. 0.12 kg

"subject to technical modifications"

*check for suitability!

Dimensions diagram

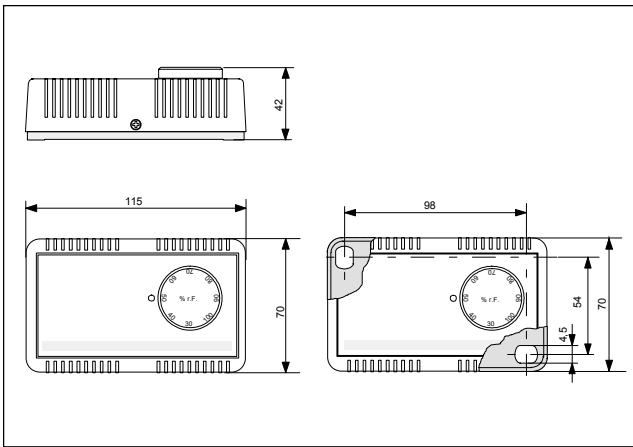

Type Survey

Type	Order No.	switching
HG120 HG120i	42042011 42042012	1 changeover switch for humidification or dehumidification
HG120-2 HG120-2i	42042221 42042222	2x changeover switch with neutral zone (adjustable) 2x humidification or dehumidification 1x humidification and 1x dehumidification

Note:
Moving the adjuster screw nullifies the guarantee.

Slot diagram

HG120

Set value adjusting knob

$F_x > F_w \leftrightarrow F_x < F_w$

ON

OFF

230VAC 5(2)A

HG120-2

Set value relative to adjusting knob

$F_x > F_w \leftrightarrow F_x < F_w$

ON

OFF

230VAC 5(2)A

adjustable zone between the steps

F_x rel. humidity of the air (process value)
F_w adjusted humidity at the set value generator (set value).
If the rel. humidity F_x falls below the adjusted set value F_w, then contact 1/4 [7/5] opens and contact 1/2 [7/6] closes.

Adjusting the 2nd set value

The hygrostats HG120-2(i) are set by the factory such that the 2nd set value is 6%rh higher than the 1st set value. The neutral zone (distance between the 1st and 2nd set value) can be adjusted after removing the housing cover using a screwdriver. If turned to the right the 2nd set value goes up, if turned to the left it goes down. As soon as the colour points of the 2nd set value regulator are facing, both microswitches are switching at the same time. The neutral zone can be read using the rotary knob.

⚠ The electrical connection must only be carried out by properly qualified personnel.

Mounting

- > The hygrostats must not come into direct contact with water, e.g. splashed water when cleaning the climatic chamber etc.
- > The mounting location should be chosen so that a representative measurement of the air humidity can be guaranteed, i.e. the humidity readings at the mounting location should correspond to those in the room as far as possible.
- > The hygrostat should be exposed to the flow of air.

Influence of the relative air humidity

at a temperature fluctuation of $\pm 1^\circ\text{C}$ referred to various room temperatures.

	10°C	20°C	30°C	50°C
10%rh	$\pm 0,7\%rh$	$\pm 0,6\%rh$	$\pm 0,6\%rh$	$\pm 0,5\%rh$
50%rh	$\pm 3,5\%rh$	$\pm 3,2\%rh$	$\pm 3,0\%rh$	$\pm 2,6\%rh$
90%rh	$\pm 6,3\%rh$	$\pm 5,7\%rh$	$\pm 5,4\%rh$	$\pm 4,6\%rh$

It is thus of extreme importance that the temperature is constant for measurements of the relative air humidity. The air must be homogenous, e.g. possess constant humidity and temperature for the whole duration of the measurement.

Notes on voltage

The measurement location of the humidity controller should be selected such that there is no build-up of condensate on or in the device. This applies particularly for operation with a voltage higher than 48V. If the voltage is higher, there is a risk of voltage arcing in the event of water condensation on the microswitch or connecting terminals which might destroy the controller. In the case of voltage below 48V, the humidity controller can be used up to 100%RH.