



Product info sheet no. B 1.7 Humidity sensing elements



Description

The MELA® **FOM 8/1-type humidity voltage converters** are OEM subassemblies which convert the humidity signal into a calibrated voltage signal.

They are available as printed circuit board modules or printed circuit boards combined with tubes and thread.

The advantages of it are:

- compact dimensions
- calibrated output signal
- temperature measuring element can be retrofitted
- low operating voltage
- low power consumption
- attractive price

Use of capacitive humidity sensor elements is a guarantee of:

- high long-term stability
- almost linear characteristic curve
- good dynamic performance
- resistance to dew formation
- low temperature coefficients
- small hysteresis.

User instructions

Install the MELA®-**humidity voltage converter** at a place in or on the equipment where characteristic levels of humidity can be measured. Avoid installing it close to heaters in places where it is likely to be splashed. Ensure that the sensing element is in a well ventilated area.

Dew formation and deposits of dust do not cause any harm however, they may affect dynamic performance.

Do not touch the highly sensitive sensor element.

Intrinsic capacity (construction parts connected with earth) can result in additional error.

Please consult the **application instructions for the sensing elements** (product info sheet no. A 1) or check with the manufacturer for further information which you need to bear in mind when using humidity sensors with capacitive sensing elements.

Technical data

Humidity

Measuring element	FE09.R/4
Measuring range	0...100%rh
Accuracy (MR 20...85% rh at 23°C, 1m/s)	±3% rh
Response time	10s
Ambient temperature	-20...+80°C

Other data

Operating voltage	8...10V
Power consumption	<1mA
Load resistance	2.5 MOHM
Current-output	acc. diagram
Weight	ca. 3g

"subject to technical modifications"

Dimensions

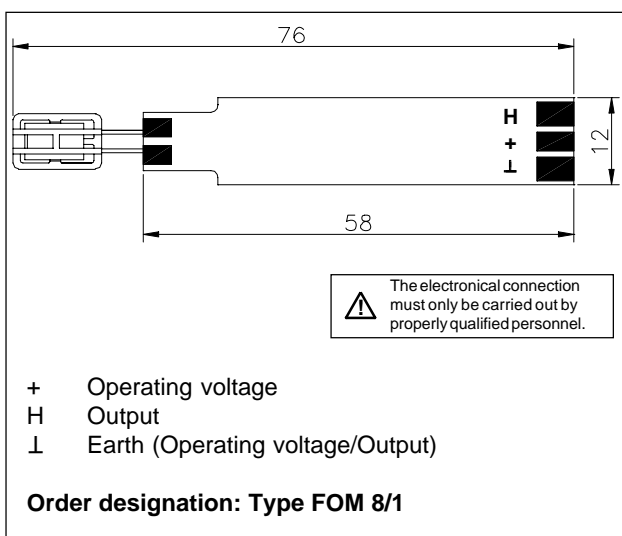

Voltage at the output as a function of relative humidity:

