



Product info sheet no. C 4.7 - Series -ME
Humidity / temperature sensors
 IP65 - for wall mounting

Description

MELA®-humidity/-temperature sensors in this series are supplied with a robust aluminium die cast housing with an aluminium sensor part to measure relative humidity and temperature in air and other non-aggressive gases. The sensor is suitable for outdoor use.

The advantages of the series .../9 are its improved dynamics, in particular at low air speeds and also its increased service life, even under more challenging operating conditions (pollutant impact or permanent humidity > 95 %rh).

When air speeds are extremely high combined with a high number of particles, using the series .../9 is not recommended.

For extreme applications (near the sea, desert, mountains, areas with high air speed etc.) we recommend our stainless steel sinter filter **types ZE 21** resp. **ZE 22** (not recommended for the series .../9, see product info sheet F 5.1).

Type Versions (order designation)

Measured variable	Analogue output	with filter ZE 20 Pt-100 platinum chip	with integrated PTFE filter protection ZE 16, Pt-100 glass
F rel. humidity	0 ... 10 V	FGC2/5-ME	FGC2/9-ME
	4 ... 20 mA	FGC3/5-ME	FGC3/9-ME
C r.h. + t (passive)	0 ... 10 V , Pt-100	CGC2/5-ME	CGC2/9-ME
	4 ... 20 mA, Pt-100	CGC3/5-ME	CGC3/9-ME
K r.h. + t (active)	2x 0 ... 10 V	KGC2/5-ME	KGC2/9-ME
	2x 4 ... 20 mA	KGC3/5-ME	KGC3/9-ME
T temperature	Pt-100	TGC5/5-ME	TGC5/9-ME
	0 ... 10 V	TGC2/5-ME	TGC2/9-ME
	4 ... 20 mA	TGC3/5-ME	TGC3/9-ME
weight		approx. 470 g	

Special versions available on request.

Technical data

Humidity

measuring range 0...100% rh
 accuracy (10...40°C; 5...95% rh) ±2% rh
 influence of temperature <10°C, >40°C <0.1%/K

Temperature

measuring element Pt 100 class 1/3-DIN
 measuring range -30...+70 °C

accuracy output: 0...10 V3/4-wire ±0.2 K
 output: 4...20 mA ...2-wire ±0.3 K
 influence of temperature <10°C, >40°C ±0.007 K/K

Other data

ambient temperature -40...+80 °C
 operating voltage
 current output 12...30V DC
 voltage output 24V±10% AC
 or 15...30 V DC
 degree of protection IP 65
 housing material
 sensor part aluminium
 transformer part pressure die casting of alu
 external load (voltage output) ≥10kΩ
 external load (current output) acc. diagramm
 power consumption (voltage output) < 5mA
 minimum air speed across the sensor
 output: 0 ... 10V, 2x 0 ... 1V ≥ 0.5 m/s
 4 ... 20mA, 2x 0 ... 10V ≥ 1.0 m/s
 2x 4 ... 20mA ≥ 1.5 m/s
 self-heating coefficient Pt100 (v=2m/s in air) 0.2K/mW
 electromagnetic compatibility according to EN 61326-2-3

Working range for humidity

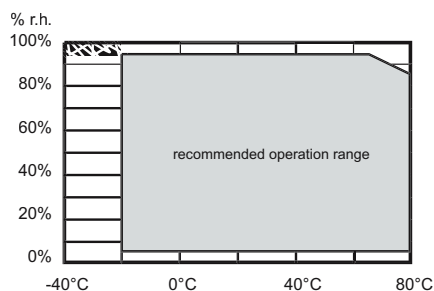

Operating the sensor in these areas can damage it!

User instructions

Install the Mela®-humidity/temperature sensors at a place in the room, plant or equipment where characteristic levels of humidity occur. Avoid installing them close to heaters or windows or against outside walls.

The specified minimum air speeds and - with current output - the load according to the operating voltage (diagram) should be complied with. Deviations may lead to additional measuring faults resulting of the self-heating of the sensor.

When installing the sensor, do avoid positions where water ingress can occur. Dew formation and splashes do not damage the sensor, although corrupted measurement readings are recorded until all the moisture on and directly around the sensor element has dried up.

In order to maintain interference immunity in accordance with EN 61326-2-3 when it is in use, we recommend that you use a screened cable (type recommended: **8x AWG 26 C UL order no. 5339**) for connecting the sensors and have this fitted into the sensor's EMC heavy-gauge conduit thread by a qualified electrician.

Dust does not cause any harm to the humidity sensor, however, it does affect dynamic performance. If there is an excessive build-up of dust on the sensor element, you can blow it off or rinse it carefully with distilled water. It is important not to touch the highly sensitive sensor element in the process.

For suitable mounting supports and other accessories please refer to our product info sheet no. F 5.1.

Please consult the **application instructions for the sensing elements** (product info sheet no. A 1) or check with the manufacturer for further information which you need to bear in mind when using humidity sensors with capacitive sensing elements.

External load / current output

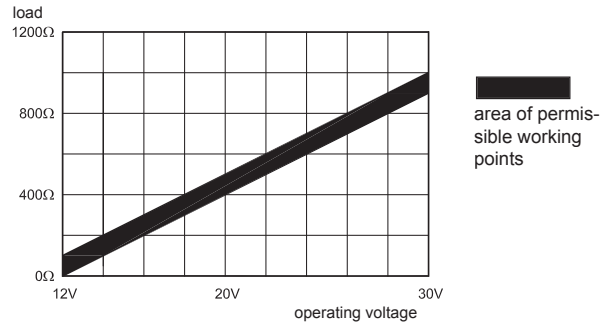

Dimensions and Fitting Instructions

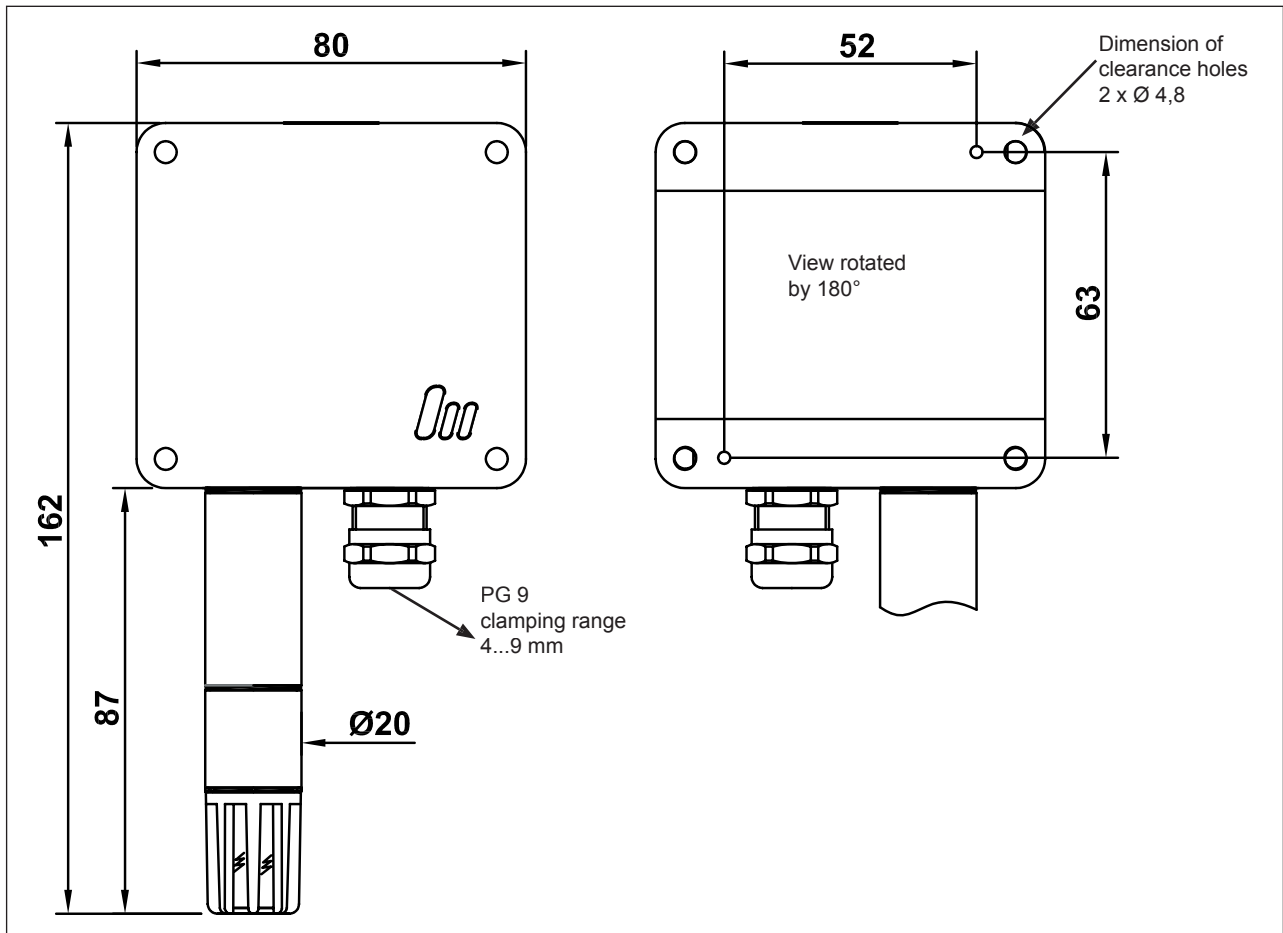

Connecting diagram

Humidity/- temperature sensors Meteorological design

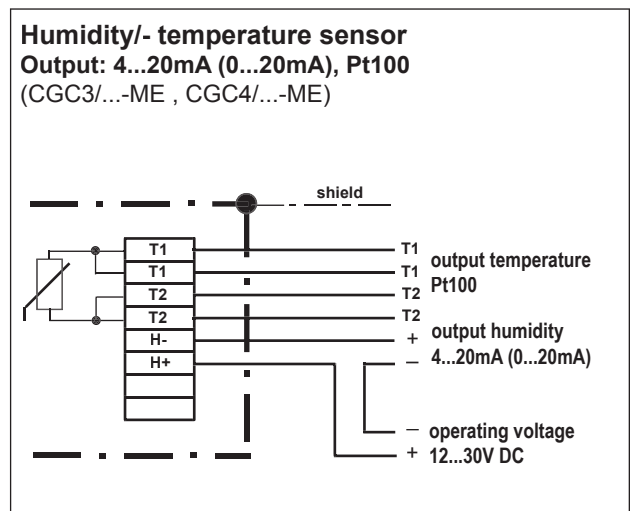
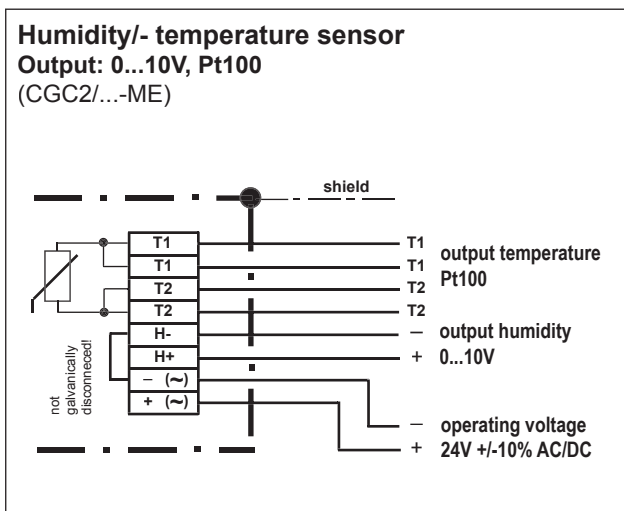
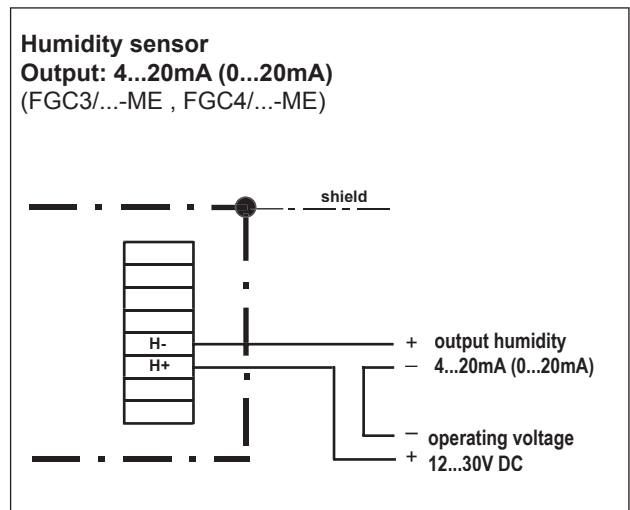
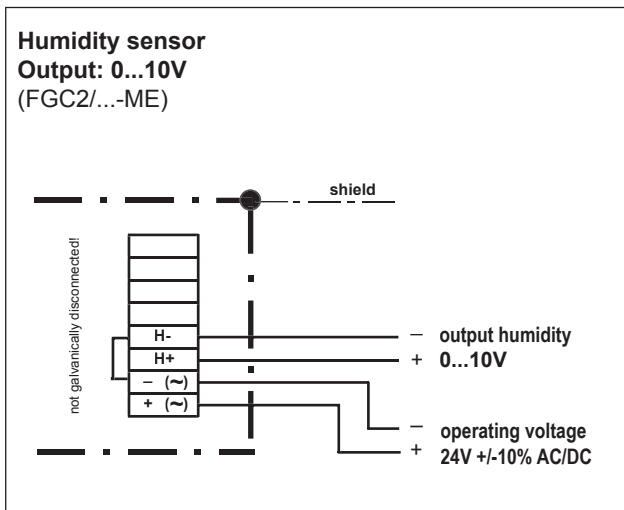
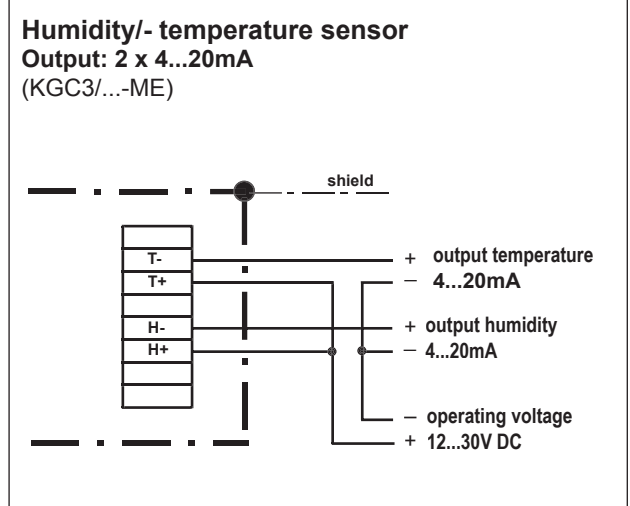
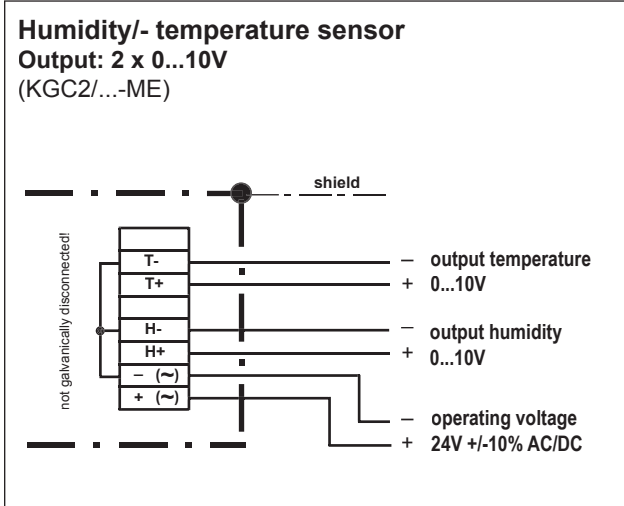

Connecting diagram

Humidity/- temperature sensors Meteorological design

