



Product info sheet no. A1

Application notes for humidity sensing elements

Measuring principle

The **MELA-humidity sensing elements** work according to the capacitive measuring principle. A humidity-dependent capacitor is developed by means of a suitable system of layers, comprising a base ceramic substrate, a system of electrodes, a layer of gold which is permeable to water vapour and a humidity-sensitive polymer. The capacity of this capacitor is a measure of the ambient relative humidity.

The particular advantages of these humidity sensing elements are:

- almost linear characteristic line
- excellent dynamic behaviour
- hygrostability and, thus,
- capability of being used within the entire humidity range.

Measurement range

The **MELA-humidity sensing elements** can be used within the entire measuring range from 0...100% RH. Their hygrostability also renders them dew-proof, i.e. condensed water on the surface of the element does not cause any damage. However, its characteristic curve is not linear while there is water on the element. Applicable measurement readings are only displayed again once the elements have dried.

In continuous operation mode, the elements should be used up to an absolute humidity level which corresponds to a dew-point temperature of 60°C. The elements can be used at dew-point temperatures of up to 90°C during short work cycles.

Thermal load capability

The **MELA-humidity sensing elements** can be used within a temperature range of -60 to 200°C.

The measuring range is limited at temperatures in excess of 100°C because the relative humidity which is theoretically possible gradually decreases at normal pressure. It is approx. 8% RH at 200°C.

When using humidity sensing elements with a protective frame (FE09.R/x), types can be used at temperatures of between -40 and 110°C.

When the sensing element is being soldered in, ensure that the contact points are not exposed to an excessive thermal load. We advise you to touch the connecting wires with a pair of pliers or tweezers in order to draw off the heat more effectively. Use extra-low voltage soldering iron for soldering in (soldering temperature 240°C, max. soldering time 2 seconds).

Mechanical sensitivity

The layered structure of the sensing element includes the thin polymer layer as well as a wafer-thin layer of gold, both of which are very sensitive to external mechanical influences. Even the finest scratches damage the sensing element. Therefore, never touch the surface of the sensing element.

Particles carried along in the airflow (such as sand) can also destroy the sensing element. The element can be protected by using an appropriate filter made from sintered metal or PTFE.

Some types of **MELA-humidity sensing elements (FE 09/1, FE 09/1000)** have a protective layer which reduces their mechanical sensitivity.

Most **MELA-humidity sensing elements** also can be supplied with a protective frame in order to protect the sensitive surface, making it easier to handle.

Connection conditions

The maximum voltage measured at the element is 3 V, and the measured frequency should be between 5 kHz and 200 kHz; this frequency should be between 5 kHz and 100 kHz in the case of the FE 09/1000. Avoid connecting a DC voltage supply.

Linearity

The deviation in linearity across the entire measuring range is less than 1.5% RH. There is generally no need for linearisation by means of the evaluation circuit.

Temperature-dependence

The temperature-dependence of the humidity sensing elements is less than 0.1% RH/K; this is negligible in an average temperature range of between 10 and 40°C. At temperatures outside this range, the measuring accuracy can be improved by means of temperature compensation in the evaluation circuit.

The following correction algorithm can be specified for the temperature-dependence of the humidity sensing elements.

$$K = [A + a(T - 25)] \cdot \sum_{i=0}^2 b_i \cdot T^i$$

K = corrected value

A = output signal (0...100% rh)

T = temperature in °C

a = 0,04 (for T ≥ 25°C)

a = 0 (for T < 25°C)

b₀ = 0,98125

b₁ = 6·10⁻⁴

b = 6·10⁻⁶

Dynamic behaviour and hysteresis

MELA-humidity sensing elements react instantly to changes in ambient humidity. The response time (T90) is less than 10 seconds. Recovery of the final value (approx. 1% RH) depends on the air speed and on the length of time the previous humidity remains for. In a humidity range of 20...90% RH, the hysteresis is less than 1% RH. The hysteresis may be up to 2% RH if the sensing elements are exposed to extremely dry or humid conditions (relative humidity < 20% or > 90% RH) for a long period of time.

Storage influences

If the sensing elements are stored for weeks at a time in conditions of extremely low humidity (<25% RH) or high humidity (>90% RH), the gradient of the sensing elements changes. However, this returns to its original value by running through the entire humidity range a number of times.

Before the humidity sensing elements are ultimately put into use and before calibration with an evaluation circuit, they should be stored for at least 48 hours at a relative humidity of 60...80%.

Dirt

Non-hygroscopic deposits, such as dust, on the active surface do not impair the function of the humidity sensing elements, although they can hamper the dynamic performance if the deposits are too large.

Hygroscopic deposits, such as salts, affect the function of the humidity sensing elements by raising conductivity and causing measuring errors, which can sometimes prove to be significant, in particular within the range of high humidity. Dry dust can simply be blown off. Elements with hygroscopic deposits can only be cleaned by washing them with distilled water. In the case of humidity sensing elements with an additional protective layer (FE 9/1, FE09/1000), stubborn dirt can be removed by brushing on distilled water with a very soft brush.

The elements can be used again after cleaning, provided they have sustained no mechanical damage.

Influence of harmful substances

Harmful substances can have very different effects on humidity sensing elements. Many harmful substances, such as acids have no affect on the element .

Some harmful substances are not damaging to the element, however they can corrupt measurement readings; this occurs, in particular, in high humidity but disappears again when atmospheric conditions return to normal.

Other harmful substances bring about a change in the gradient of the characteristic curve, which can only be reversed by thermal treatment (heating up), whereby the molecules of the harmful substances are drained out (formaldehyde, carbon dioxide, alcohol etc.).

There are a few harmful substances, however, which bring about irreversible changes in the characteristic curve or damage the element (ammonia, bases, etc.). We advise you not to use the sensing elements in these conditions.

Unfortunately it is not possible for us to test all harmful substances and the effect they have on our elements. The database of tested substances we have at our disposal is continuously being expanded and made more precise. If you have any applications subject to pollution, please contact us.

Subject to technical modifications.

Application circuits with a frequency output

- Discrete circuit:

Humidity sensing elements: types FE09/1, FE09/2, FE09/4

5 ... 95%rh correspond to approx. 54...47

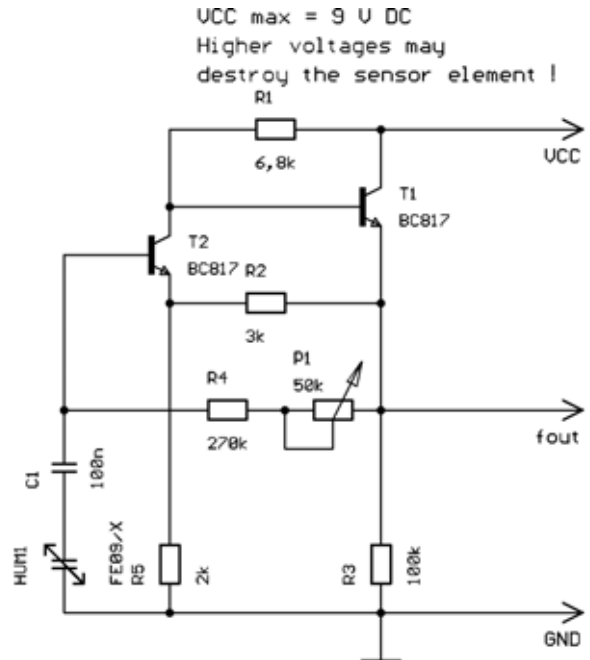

- Circuit with 555

Humidity sensing elements: types FE09/1, FE09/2, FE09/4

5 ... 95%rh correspond to approx. 33...27kHz

Humidity sensing elements: types FE09/1000

5...95%rh correspond to approx. 3...2 kHz

